

ICE128M150W4 Silicon Carbide Power MOSFET

Product Summary			
I_D	$T_A=25^\circ\text{C}$	19A	Max
$V_{(BR)DSS}$	$T_C=25^\circ\text{C}$	1500V	Min
$r_{DS(on)}$	$V_{GS}=18\text{V}$	128m Ω	Typ
Q_g	$V_{DS}=1000\text{V}$	24nC	Typ

Features

- 1500V 128mohm SiC MOSFET
- High blocking voltage with low on-resistance
- High-speed switching with low capacitances
- Fast Reverse Recovery
- Optimized design for high performance power systems



Lead Free

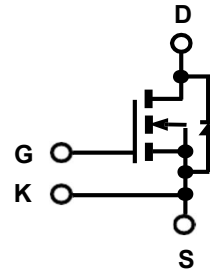

TO247-4L

1: D, 2: S,
3: K, 4: G

Maximum ratings^a, at $T_j=25^\circ\text{C}$, unless otherwise specified

Parameter	Symbol	Conditions	Value	Unit
Continuous drain current	I_D	$T_c=25^\circ\text{C}$	19	A
		$T_c=100^\circ\text{C}$	13	
Pulsed drain current	$I_{D, \text{pulse}}$		61	A
Maximum gate source voltage	$V_{GS(max)}$		-10/+22	V
Operational gate source voltage	$V_{GS \text{ op}}$		-5/+18	V
Power dissipation	P_{tot}	$T_c=25^\circ\text{C}$	116	W
		$T_c=100^\circ\text{C}$	58	
Storage temperature	T_{stg}		-55 to +150	$^\circ\text{C}$
Operating temperature	T_j		-55 to +175	$^\circ\text{C}$

^a Pulse width limited by T_{jmax}

Parameter	Symbol	Conditions	Values			Unit
			Min	Typ	Max	

Thermal characteristics

Thermal resistance, junction-case	R_{thJC}		-	-	1.29	°C/W
Soldering temperature, wave soldering only allowed at leads	T_{sold}	1.6mm (0.063in.) from case for 10 s	-	-	260	°C

Electrical characteristics ^a, at $T_j=25^{\circ}\text{C}$, unless otherwise specified

Static characteristics

Drain-source breakdown voltage	$V_{(BR)DSS}$	$V_{GS}=0V$	1500	-	-	V
Gate threshold voltage	$V_{GS(th)}$	$V_{DS}=V_{GS}, I_D=2.8mA, T_j=25^{\circ}\text{C}$	2	2.6	4	
		$V_{DS}=V_{GS}, I_D=2.8mA, T_j=175^{\circ}\text{C}$	-	1.9	-	
Zero gate voltage drain current	I_{DSS}	$V_{DS}=1500V, V_{GS}=0V, T_j=25^{\circ}\text{C}$	-	0.1	50	μA
		$V_{DS}=1500V, V_{GS}=0V, T_j=175^{\circ}\text{C}$	-	5	-	
Gate source leakage current	I_{GSS}	$V_{GS}=-10/+22V, V_{DS}=0V$	-	-	±100	nA
Drain-source on-state resistance	$R_{DS(on)}$	$V_{GS}=18V, I_D=10A, T_j=25^{\circ}\text{C}$	-	128	166	mΩ
		$V_{GS}=18V, I_D=10A, T_j=175^{\circ}\text{C}$	-	248	-	
Gate resistance	R_G	$f=1\text{ MHz}, V_{AC}=30mV$	-	5.4	-	Ω

Dynamic characteristics

Input capacitance	C_{iss}	$V_{DS}=1200V, V_{GS}=0V, f=100\text{ kHz}, V_{AC}=30mV$	-	609	-	pF
Output capacitance	C_{oss}		-	27	-	
Reverse transfer capacitance	C_{rss}		-	6.6	-	
C_{OSS} stored energy	E_{oss}		-	26	-	μJ
Forward transconductance	g_{FS}	$V_{DS}=20V, I_D=10A$	-	6.3	-	S
Turn-on delay time	$t_{d(on)}$	$V_{DS}=1000V, V_{GS}=-5/+18V, I_D=10A, R_G=10\Omega$ (External), $T_j=25^{\circ}\text{C}$	-	4.1	-	ns
Rise time	t_r		-	14	-	
Turn-off delay time	$t_{d(off)}$		-	12	-	
Fall time	t_f		-	16	-	
Turn-on switching energy	E_{ON}		-	155	-	μJ
Turn-off switching energy	E_{OFF}		-	41	-	

Parameter	Symbol	Conditions	Values			Unit
			Min	Typ	Max	

Dynamic characteristics

Turn-on delay time	$t_{d(on)}$	$V_{DS}=1000V, V_{GS}=-5/+18V,$ $I_D=10A, R_G=10\Omega$ (External) $T_j=175^\circ C$	-	3.7	-	ns
Rise time	t_r		-	15	-	
Turn-off delay time	$t_{d(off)}$		-	14	-	
Fall time	t_f		-	16	-	
Turn-on switching energy	E_{ON}		-	222	-	μJ
Turn-off switching energy	E_{OFF}		-	36	-	

Gate Charge Characteristics

Gate to source charge	Q_{gs}	$V_{DS}=1000V, I_D=10A,$ $V_{GS}=-5$ to $+18V$	-	6.6	-	nC
Gate to drain charge	Q_{gd}		-	8.3	-	
Gate charge total	Q_g		-	24	-	

Reverse Diode

Continuous forward current	I_S	$V_{GS}=-5V$	-	19	-	A
Diode forward voltage	V_{SD}	$V_{GS}=-5V, I_{SD}=5A, T_j=25^\circ C$	-	3.3	-	V
		$V_{GS}=-5V, I_{SD}=5A, T_j=175^\circ C$	-	3.1	-	
Reverse recovery time	t_{rr}	$V_{GS}=-5V, V_{RR}=1000V,$ $I_{SD}=10A,$ $d_{iF}/d_t=4390 A/\mu s, T_j=25^\circ C$	-	18	-	ns
Reverse recovery charge	Q_{rr}		-	186	-	nC
Peak reverse recovery current	I_{rm}		-	18	-	A
Reverse recovery time	t_{rr}	$V_{GS}=-5V, V_{RR}=1000V,$ $I_{SD}=10A,$ $d_{iF}/d_t=5320 A/\mu s, T_j=175^\circ C$	-	19	-	ns
Reverse recovery charge	Q_{rr}		-	408	-	nC
Peak reverse recovery current	I_{rm}		-	31	-	A

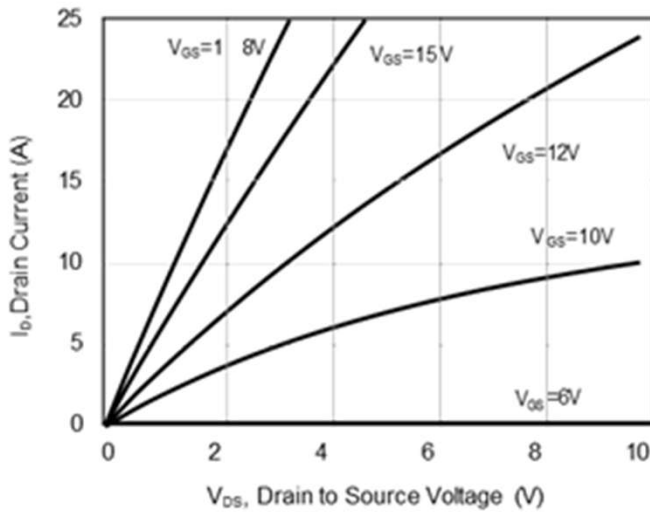

Fig 1. Output Characteristics, $T_j = -55^\circ\text{C}$

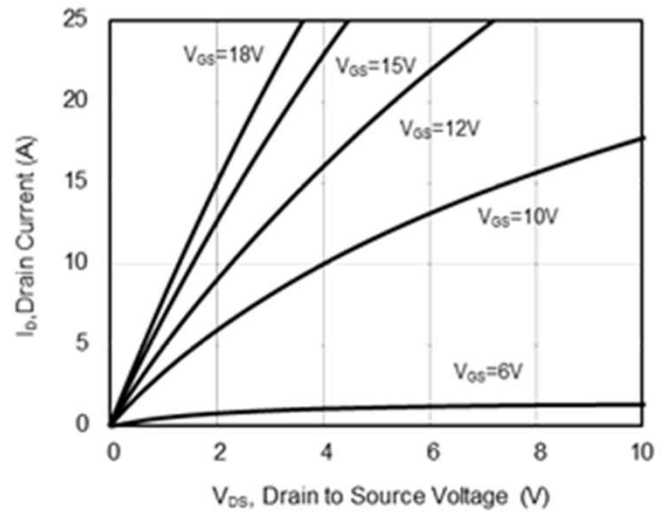

Fig 2. Output Characteristics, $T_j = 25^\circ\text{C}$

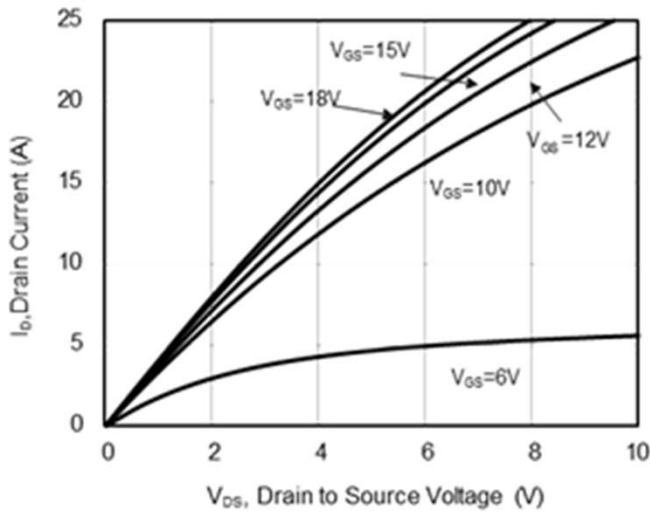

Fig 3. Output Characteristics, $T_j = 175^\circ\text{C}$

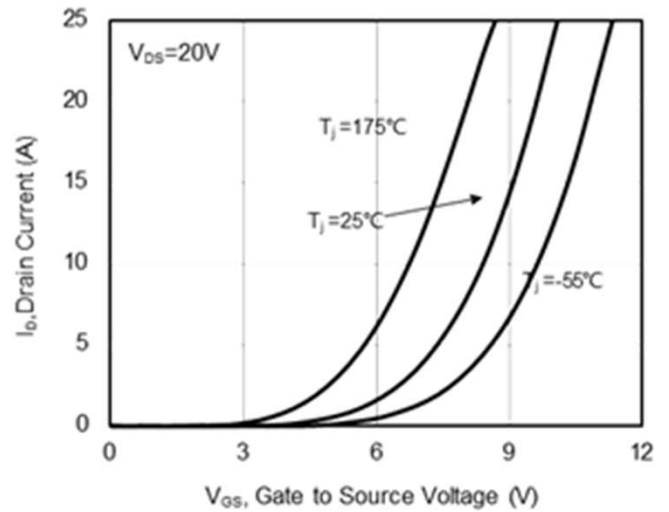

Fig 4. Transfer Characteristics

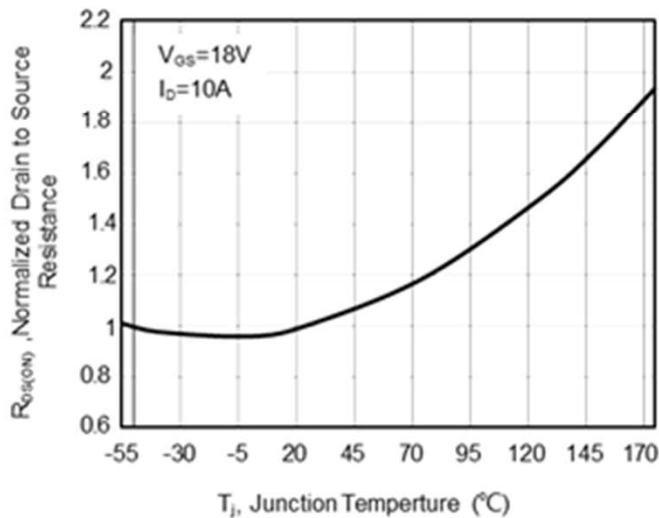

Fig 5. On-Resistance Variation with Temperature

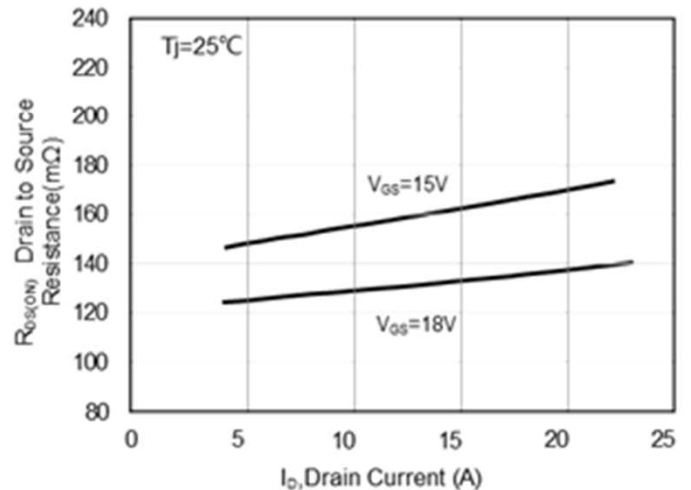

Fig 6. On-Resistance vs Drain Current

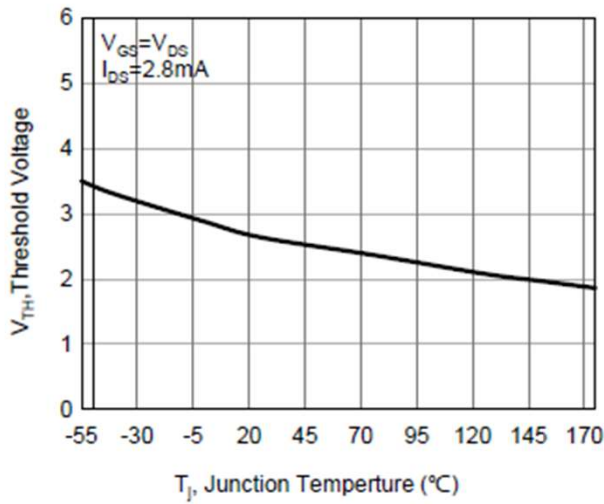

Fig 7. Gate Threshold vs Temperature

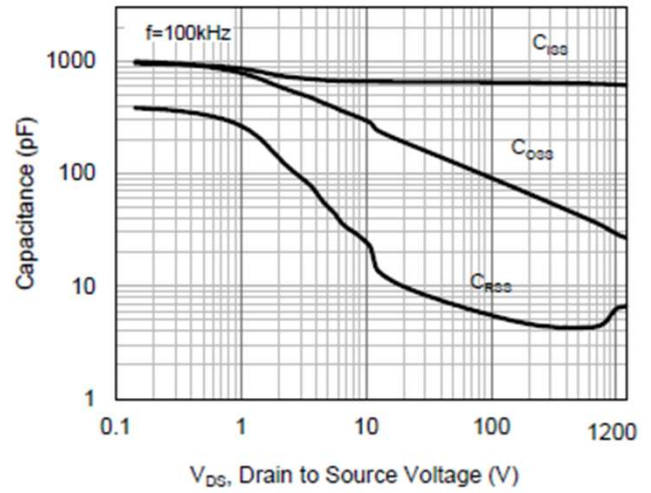

Fig 8. Capacitance Characteristics

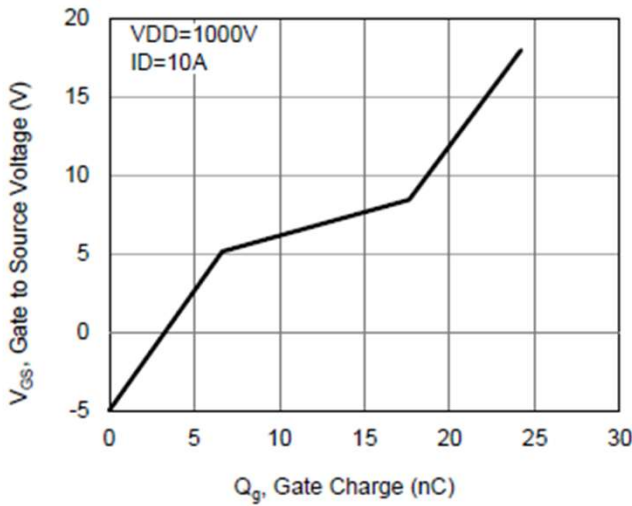

Fig 9. Gate Charge Characteristics

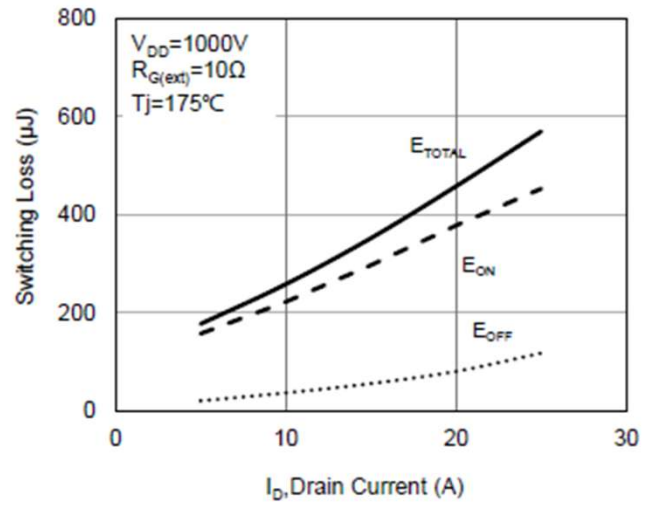

Fig 10. Switching Energy vs. Drain Current

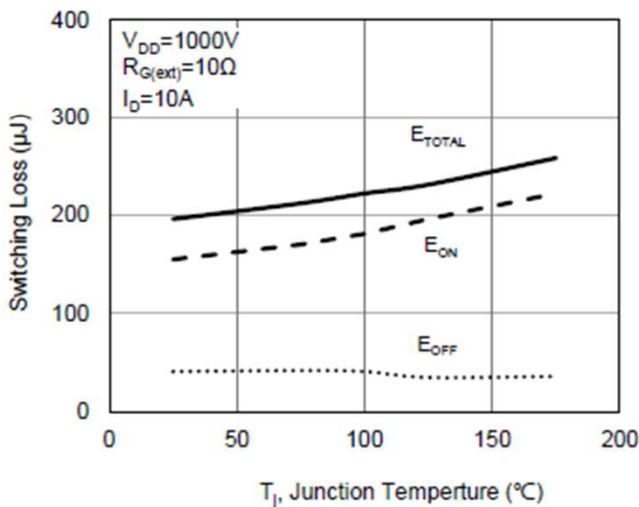

Fig 11. Switching Energy vs. Temperature

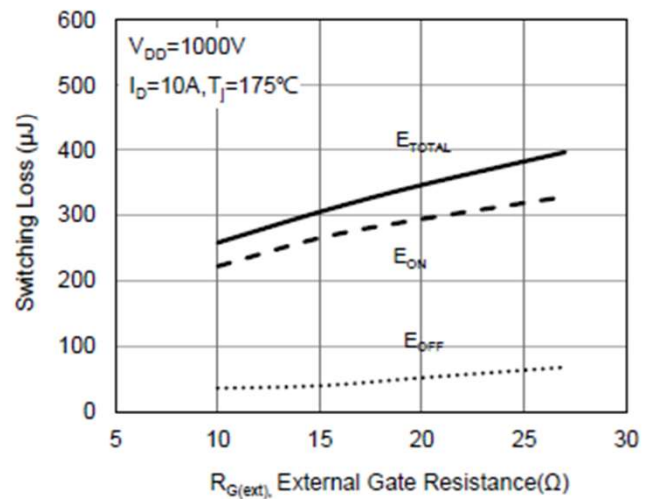

Fig 12. Switching Energy vs. Gate Resistance

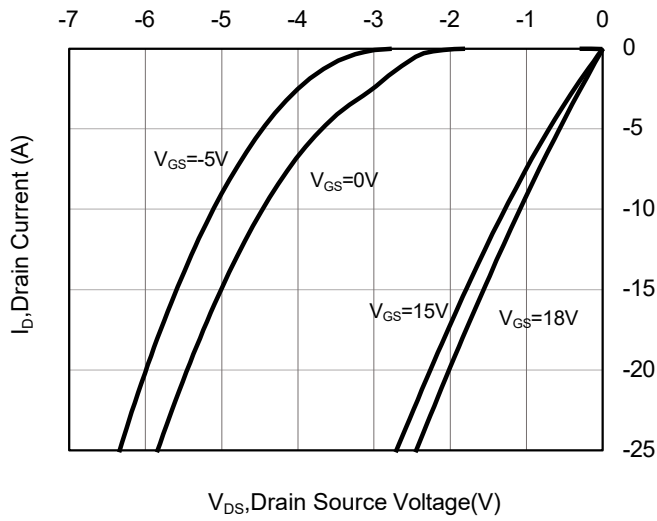

Fig 13. 3rd Quadrant Characteristic at -55 °C

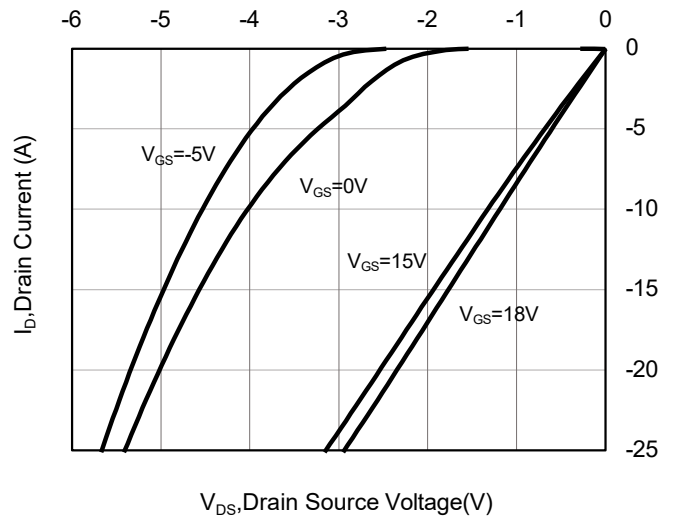

Fig 14. 3rd Quadrant Characteristic at 25 °C

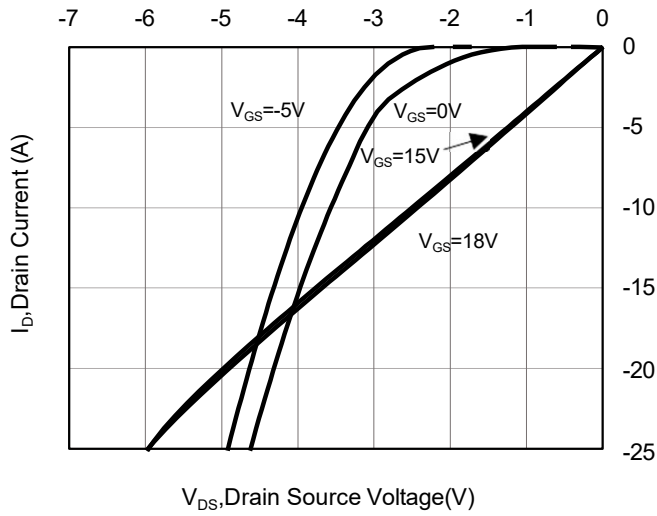
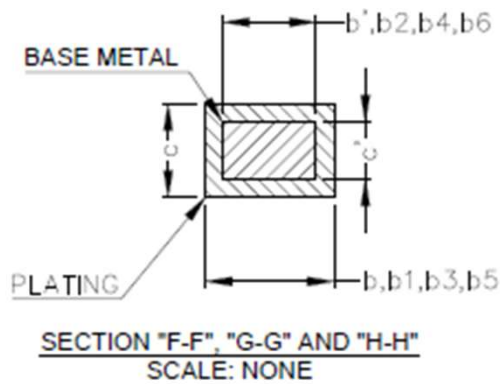
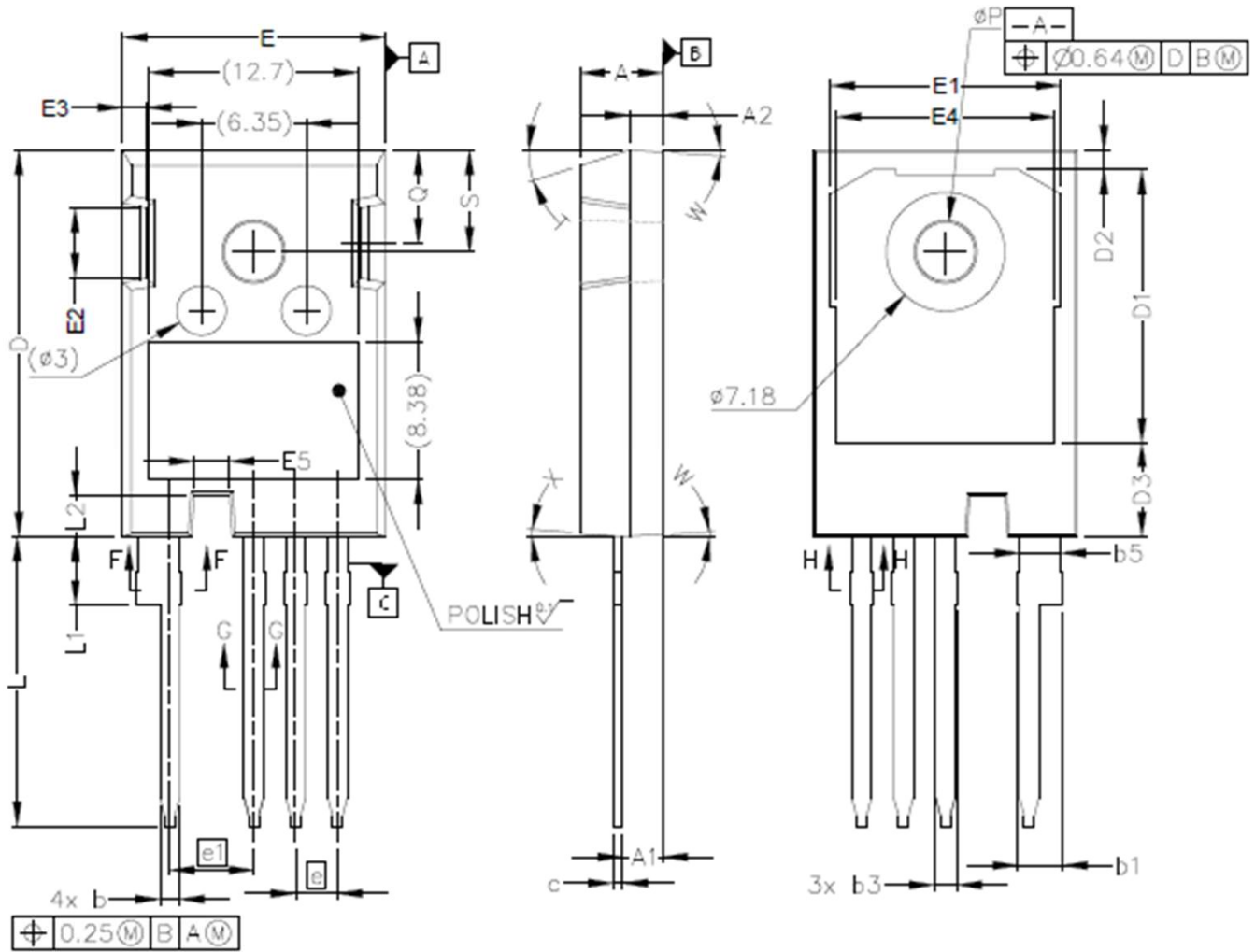

Fig 15. 3rd Quadrant Characteristic at 175 °C

Package Outline: TO-247-4L



Package Outline: TO-247-4L

NOTE :

1. ALL METAL SURFACES: TIN PLATED EXCEPT AREA OF CUT
2. DIMENSIONING & TOLERANCING CONFIRM TO ASME Y14.5M-1994.
3. ALL DIMENSIONS ARE IN MILLIMETERS. ANGLES ARE IN DEGREES.

SYMBOL	MILLIMETERS	
	MIN	MAX
A	4.83	5.21
A1	2.29	2.54
A2	1.91	2.16
b'	1.07	1.28
b	1.07	1.33
b1	2.39	2.94
b2	2.39	2.84
b3	1.07	1.60
b4	1.07	1.50
b5	2.39	2.69
b6	2.39	2.64
c'	0.55	0.65
c	0.55	0.68
D	23.30	23.60
D1	16.25	17.65
D2	0.95	1.25
D3	5.55	6.15
E	15.75	16.13
E1	13.10	14.15
E2	3.68	5.10
E3	1.00	1.90
E4	12.38	13.43
E5	1.95	2.35
e	2.54 BSC	
e1	5.08 BSC	
N	4	
L	17.31	17.82
L1	3.97	4.37
L2	2.35	2.65
øP	3.51	3.65
Q	5.49	6.00
S	6.04	6.30
T	17.5° REF.	
W	3.5° REF.	
X	4° REF.	

Marking Information

YY = Last two digits of the year

WW = Work week

***** = Site ID

XXXXXX = Lot ID

ICE128M150 = ICE is IceMOS logo and 128M150 is a designated device part number

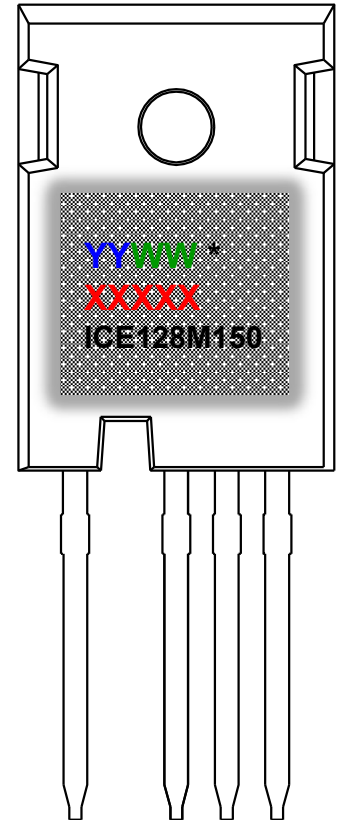

Disclaimer

Information contained in this data sheet shall in no event be regarded as a guarantee of conditions or characteristics. All product, data sheet are subject to change without notice to improve reliability. ICEMOS technology will not be responsible for damages of any nature resulting from the use or reliance upon the information contained in this data sheet.