

## ICE14M120W4 Silicon Carbide Power MOSFET

Product Summary			
$I_D$	$T_A=25^\circ\text{C}$	111A	Max
$V_{(BR)DSS}$	$T_C=25^\circ\text{C}$	1200V	Min
$r_{DS(on)}$	$V_{GS}=18\text{V}$	14.5m $\Omega$	Typ
$Q_g$	$V_{DS}=800\text{V}$	165nC	Typ

### Features

- 1200V 14.5mohm SiC MOSFET
- High blocking voltage with low on resistance
- High-speed switching with low capacitances
- Fast Reverse Recovery
- Optimized design for high performance power systems



Lead Free

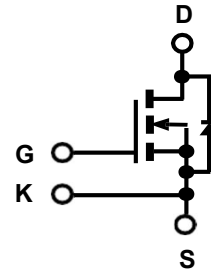

TO247-4L

1: D, 2: S,  
3: K, 4: G

**Maximum ratings**<sup>a</sup>, at  $T_j=25^\circ\text{C}$ , unless otherwise specified

Parameter	Symbol	Conditions	Value	Unit
Continuous drain current	$I_D$	$T_c=25^\circ\text{C}$	111	A
		$T_c=100^\circ\text{C}$	78	
Pulsed drain current	$I_{D, \text{pulse}}$		382	A
Maximum gate source voltage	$V_{GS(max)}$		-10/+22	V
Operational gate source voltage	$V_{GS \text{ op}}$		-5/+18	V
Power dissipation	$P_{tot}$	$T_c=25^\circ\text{C}$	441	W
		$T_c=100^\circ\text{C}$	220	
Storage temperature	$T_{stg}$		-55 to +150	$^\circ\text{C}$
Operating temperature	$T_j$		-55 to +175	$^\circ\text{C}$

<sup>a</sup> Pulse width limited by  $T_{jmax}$

Parameter	Symbol	Conditions	Values			Unit
			Min	Typ	Max	

### Thermal characteristics

Thermal resistance, junction-case	$R_{thJC}$		-	-	0.34	°C/W
Soldering temperature, wave soldering only allowed at leads	$T_{sold}$	1.6mm (0.063in.) from case for 10 s	-	-	260	°C

### Electrical characteristics<sup>a</sup>, at $T_j=25^\circ\text{C}$ , unless otherwise specified

#### Static characteristics

Drain-source breakdown voltage	$V_{(BR)DSS}$	$V_{GS}=0V, I_D=250\mu A$	1200	-	-	V
Gate threshold voltage	$V_{GS(th)}$	$V_{DS}=V_{GS}, I_D=22mA, T_j=25^\circ\text{C}$	2	2.7	4	
		$V_{DS}=V_{GS}, I_D=22mA, T_j=175^\circ\text{C}$	-	1.9	-	
Zero gate voltage drain current	$I_{DSS}$	$V_{DS}=1200V, V_{GS}=0V, T_j=25^\circ\text{C}$	-	1	10	$\mu A$
		$V_{DS}=1200V, V_{GS}=0V, T_j=175^\circ\text{C}$	-	-	50	
Gate source leakage current	$I_{GSS}$	$V_{GS}=-10/+22V, V_{DS}=0V$	-	-	$\pm 100$	nA
Drain-source on-state resistance	$R_{DS(on)}$	$V_{GS}=18V, I_D=60A, T_j=25^\circ\text{C}$	-	14.5	19	$m\Omega$
		$V_{GS}=18V, I_D=60A, T_j=175^\circ\text{C}$	-	27	-	
Gate resistance	$R_G$	$f=1\text{ MHz}, V_{AC}=30mV$	-	1.3	-	$\Omega$

#### Dynamic characteristics

Input capacitance	$C_{iss}$	$V_{DS}=800V, V_{GS}=0V, f=100\text{ kHz}, V_{AC}=30mV$	-	5096	-	$\mu F$
Output capacitance	$C_{oss}$		-	210	-	
Reverse transfer capacitance	$C_{rss}$		-	24	-	
$C_{oss}$ stored energy	$E_{oss}$		-	84	-	$\mu J$
Forward transconductance	$g_{FS}$	$V_{DS}=20V, I_D=60A$	-	46	-	S
Turn-on delay time	$t_{d(on)}$	$V_{DS}=800V, V_{GS}=-5/+18V, I_D=60A, R_G=4.7\Omega$ (External), $T_j=25^\circ\text{C}$	-	20	-	ns
Rise time	$t_r$		-	27	-	
Turn-off delay time	$t_{d(off)}$		-	51	-	
Fall time	$t_f$		-	18	-	
Turn-on switching energy	$E_{ON}$		-	0.97	-	mJ
Turn-off switching energy	$E_{OFF}$	-	0.33	-		

Parameter	Symbol	Conditions	Values			Unit
			Min	Typ	Max	

### Dynamic characteristics

Turn-on delay time	$t_{d(on)}$	$V_{DS}=800V, V_{GS}=-5/+18V,$ $I_D=60A, R_G=4.7\Omega$ (External), $T_j=175^\circ C$	-	18	-	ns
Rise time	$t_r$		-	31	-	
Turn-off delay time	$t_{d(off)}$		-	62	-	
Fall time	$t_f$		-	19	-	
Turn-on switching energy	$E_{ON}$		-	1.42	-	mJ
Turn-off switching energy	$E_{OFF}$		-	0.35	-	

### Gate Charge Characteristics

Gate to source charge	$Q_{gs}$	$V_{DS}=800V, I_D=60A,$ $V_{GS}=-5$ to $+18V$	-	47	-	nC
Gate to drain charge	$Q_{gd}$		-	44	-	
Gate charge total	$Q_g$		-	165	-	

### Reverse Diode

Continuous forward current	$I_S$	$V_{GS}=-5V$	-	111	-	A
Diode forward voltage	$V_{SD}$	$V_{GS}=-5V, I_{SD}=60A, T_j=25^\circ C$	-	4.2	-	V
		$V_{GS}=-5V, I_{SD}=60A,$ $T_j=175^\circ C$	-	3.7	-	
Reverse recovery time	$t_{rr}$	$V_{GS}=-5V, V_{RR}=800V,$ $I_{SD}=60A,$ $d_{iF}/d_t=6780 A/\mu s, T_j=25^\circ C$	-	15	-	ns
Reverse recovery charge	$Q_{rr}$		-	379	-	nC
Peak reverse recovery current	$I_{rm}$		-	42	-	A
Reverse recovery time	$t_{rr}$	$V_{GS}=-5V, V_{RR}=800V,$ $I_{SD}=60A,$ $d_{iF}/d_t=7400 A/\mu s, T_j=175^\circ C$	-	23	-	ns
Reverse recovery charge	$Q_{rr}$		-	1349	-	nC
Peak reverse recovery current	$I_{rm}$		-	84	-	A

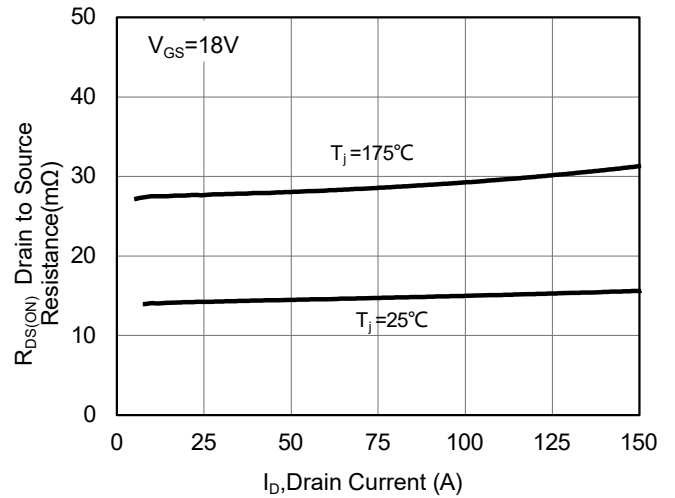
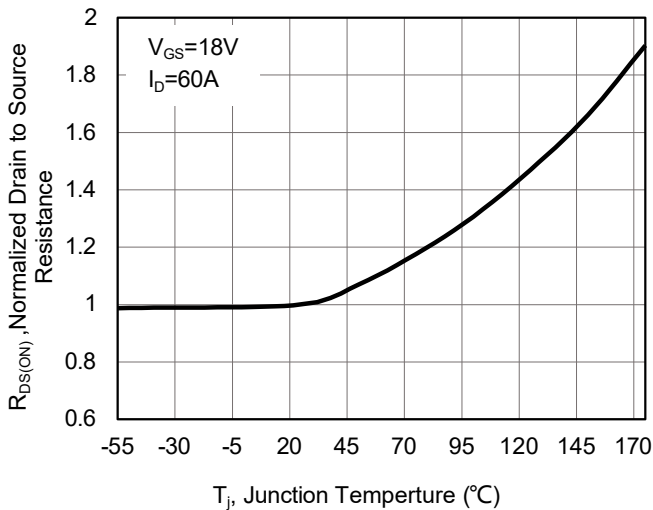
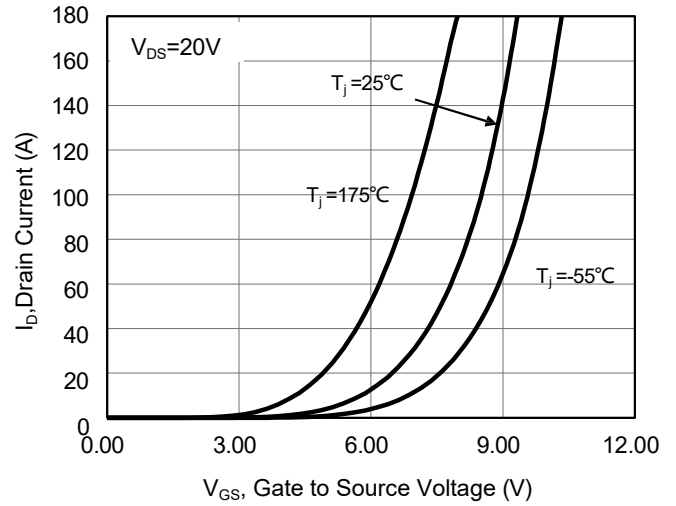
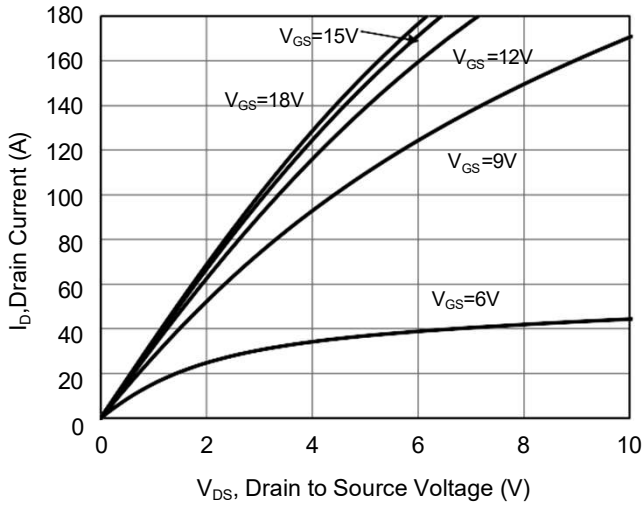
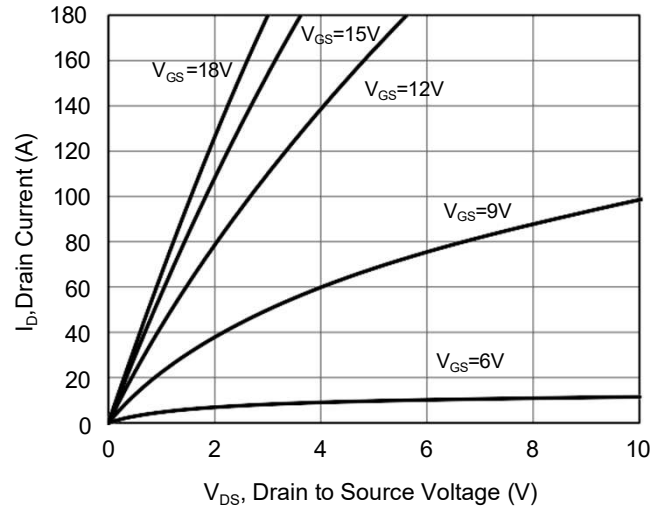
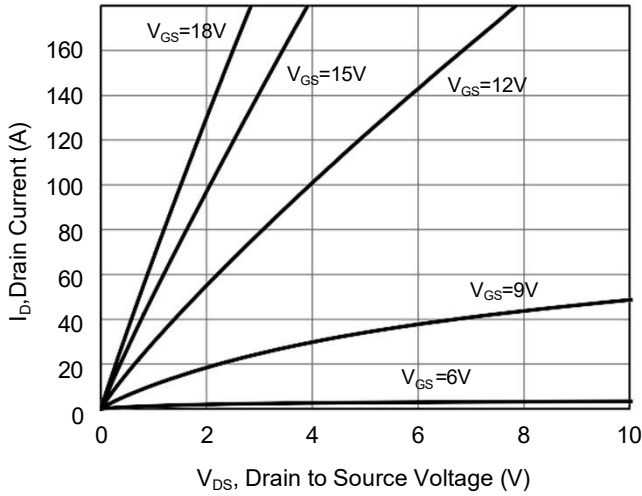

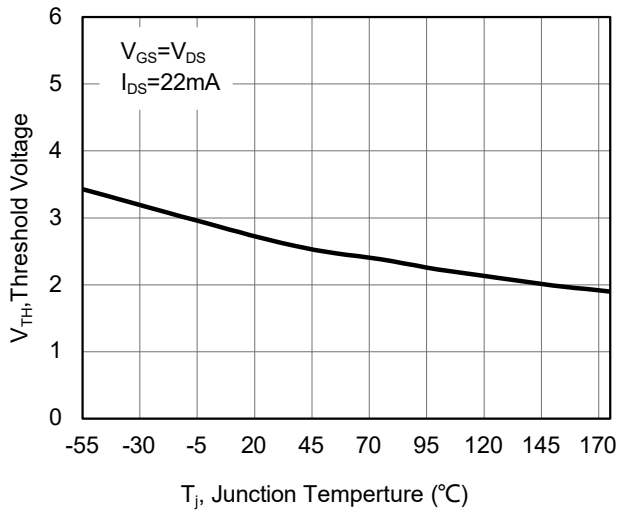

Fig 7. Gate Threshold vs. Temperature

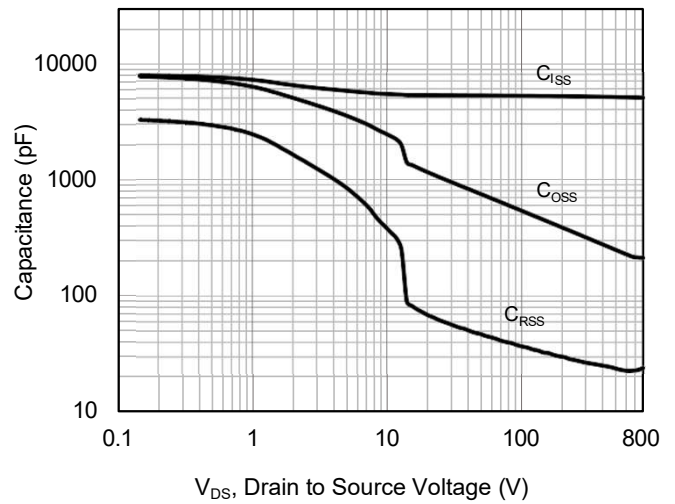

Fig 8. Capacitance Characteristics

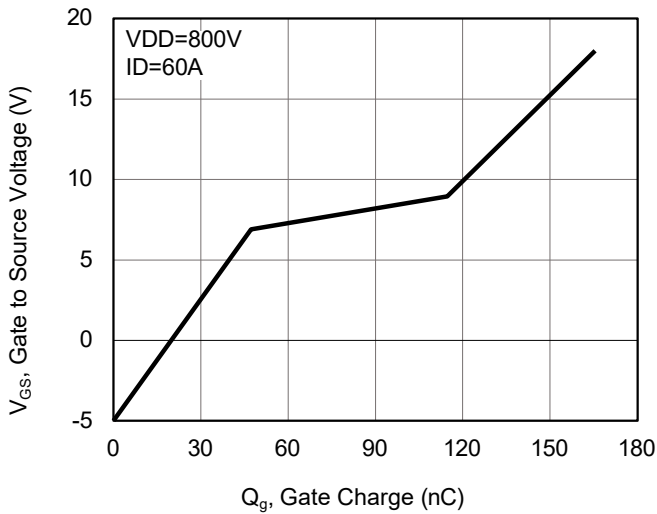

Fig 9. Gate Charge Characteristics

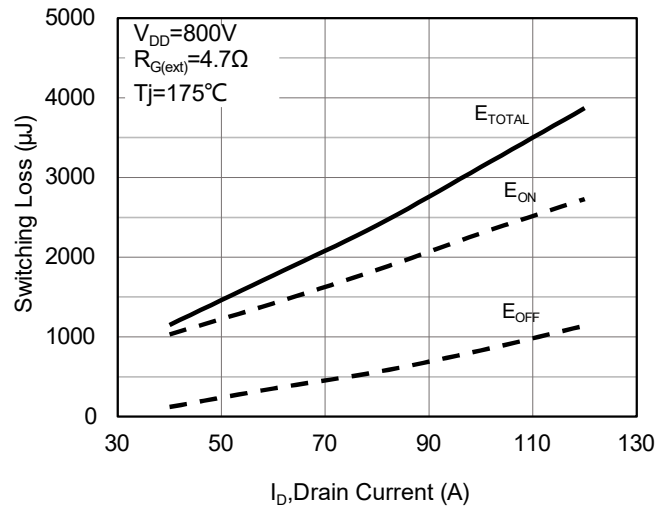

Fig 10. Switching Energy vs. Drain Current

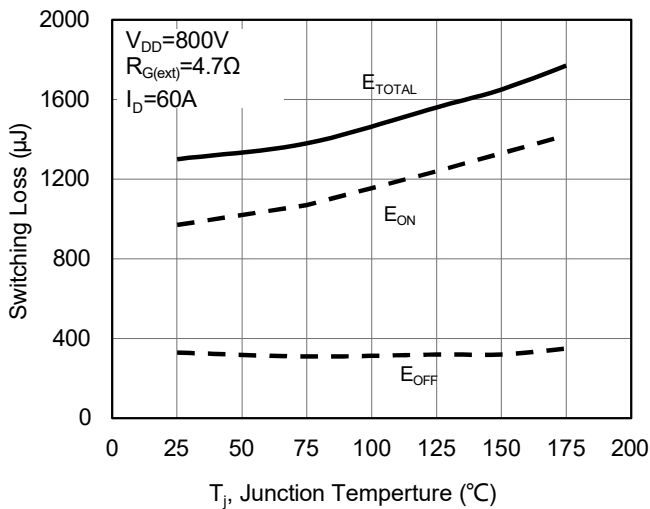

Fig 11. Switching Energy vs. Temperature

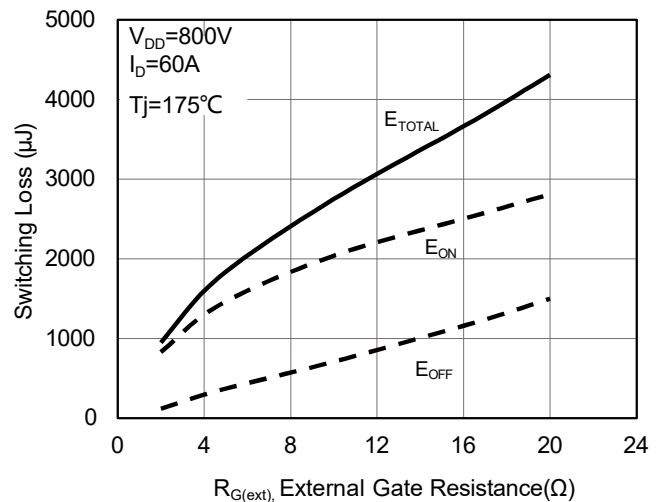

Fig 12. Switching Energy vs. Gate Resistance

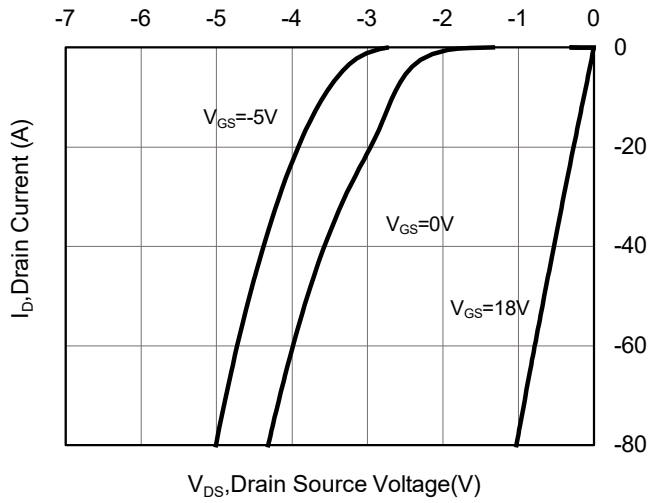

Fig 13. 3rd Quadrant Characteristic at -55 °C

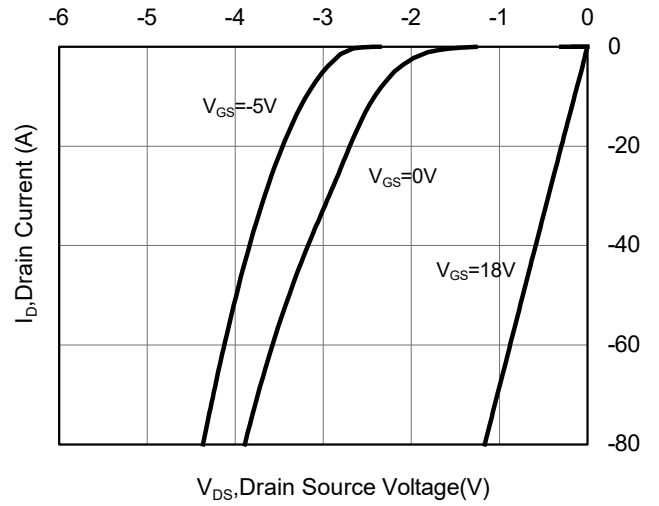

Fig 14. 3rd Quadrant Characteristic at 25 °C

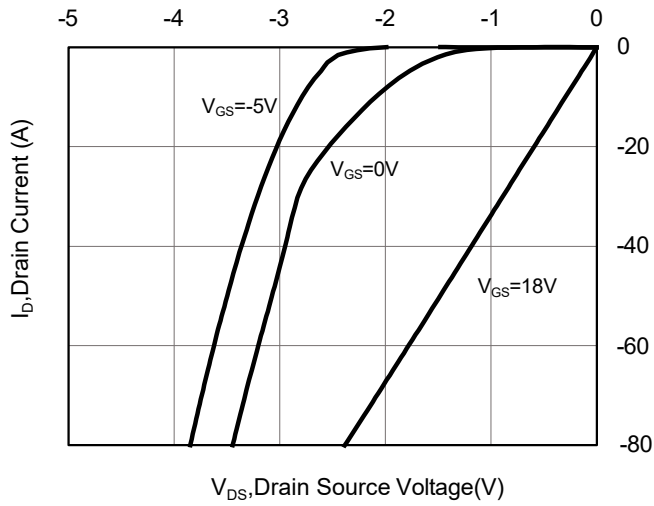
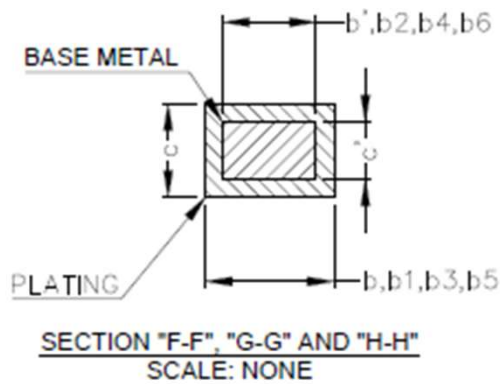
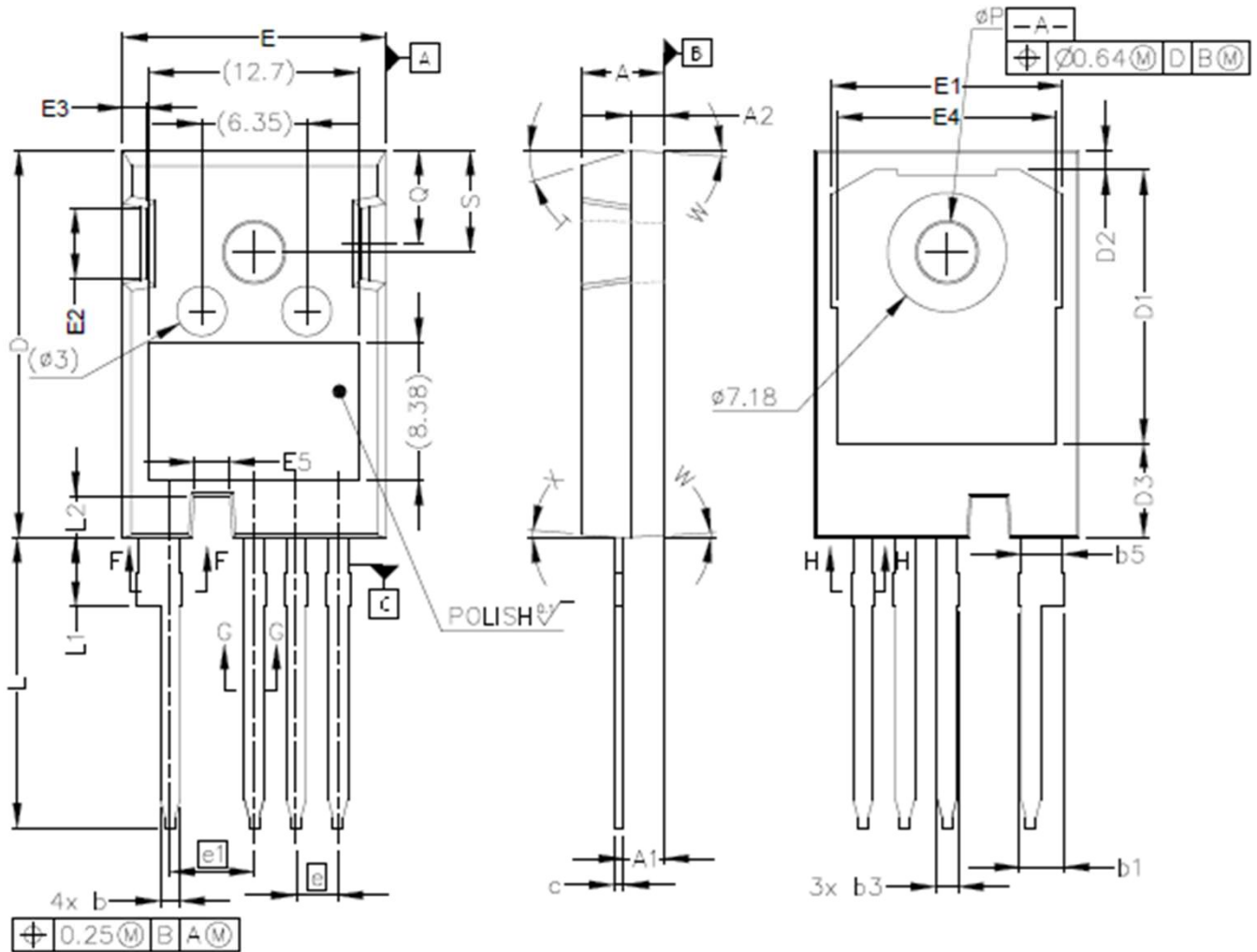

Fig 15. 3rd Quadrant Characteristic at 175 °C

Package Outline: TO-247-4L



## Package Outline: TO-247-4L

**NOTE :**

1. ALL METAL SURFACES: TIN PLATED EXCEPT AREA OF CUT
2. DIMENSIONING & TOLERANCING CONFIRM TO ASME Y14.5M-1994.
3. ALL DIMENSIONS ARE IN MILLIMETERS. ANGLES ARE IN DEGREES.

SYMBOL	MILLIMETERS	
	MIN	MAX
A	4.83	5.21
A1	2.29	2.54
A2	1.91	2.16
b'	1.07	1.28
b	1.07	1.33
b1	2.39	2.94
b2	2.39	2.84
b3	1.07	1.60
b4	1.07	1.50
b5	2.39	2.69
b6	2.39	2.64
c'	0.55	0.65
c	0.55	0.68
D	23.30	23.60
D1	16.25	17.65
D2	0.95	1.25
D3	5.55	6.15
E	15.75	16.13
E1	13.10	14.15
E2	3.68	5.10
E3	1.00	1.90
E4	12.38	13.43
E5	1.95	2.35
e	2.54 BSC	
e1	5.08 BSC	
N	4	
L	17.31	17.82
L1	3.97	4.37
L2	2.35	2.65
øP	3.51	3.65
Q	5.49	6.00
S	6.04	6.30
T	17.5° REF.	
W	3.5° REF.	
X	4° REF.	

## Marking Information

**YY** = Last two digits of the year

**WW** = Work week

**\*** = Site ID

**XXXXX** = Lot ID

**ICE14M120** = ICE is IceMOS logo and  
14M120 is a designated device part  
number

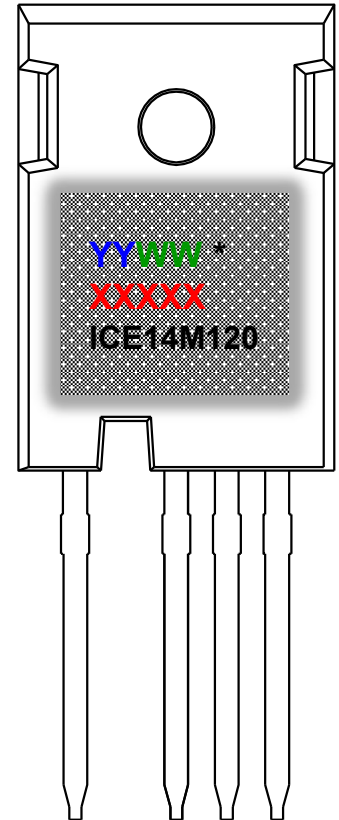

## Disclaimer

Information contained in this data sheet shall in no event be regarded as a guarantee of conditions or characteristics. All product, data sheet are subject to change without notice to improve reliability. ICEMOS technology will not be responsible for damages of any nature resulting from the use or reliance upon the information contained in this data sheet.