

ICEK35NF60 N-Channel Enhancement Mode MOSFET

Features

- Low $r_{DS(on)}$
- Ultra Low Gate Charge
- High dv/dt capability
- High Unclamped Inductive Switching (UIS) capability
- High peak current capability
- Increased transconductance performance
- Optimized design for high performance power systems

Product Summary			
I_D	$T_A=25^\circ\text{C}$	35A	Max
$V_{(BR)DSS}$	$I_D=1\text{mA}$	600V	Min
$r_{DS(on)}$	$V_{GS}=10\text{V}$	0.056	Typ
Q_g	$V_{DS}=400\text{V}$	83nC	Typ

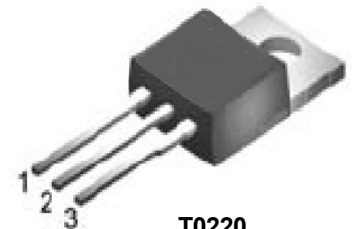
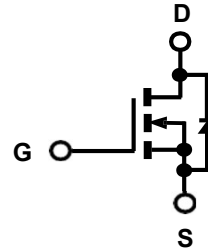

T0220

Standard Metal
Heatsink

1=Gate, 2=Drain,
3=Source.



Lead Free

Maximum ratings^a, at $T_j=25^\circ\text{C}$, unless otherwise specified

Parameter	Symbol	Conditions	Value	Unit
Continuous drain current ^b	I_D	$T_c=25^\circ\text{C}$	35	A
		$T_c=100^\circ\text{C}$	22	
Pulsed drain current ^b	$I_{D, pulse}$	$T_c=25^\circ\text{C}$	105	A
Avalanche energy, single pulse	E_{AS}	$L = 10.8 \text{ mH}, V_{DD} = 150 \text{ V}, I_{AS} = 7 \text{ A}, R_G = 50 \Omega$	264.5	mJ
Avalanche current, repetitive ^b	I_{AR}	limited by $T_j\text{max}$	7	A
MOSFET dv/dt ruggedness	dv/dt	$V_{DS}=400\text{V}, T_j=125^\circ\text{C}$	120	V/ns
Reverse diode dv/dt ruggedness			70	
Gate source voltage	V_{GS}	Static	± 30	V
		AC ($f>1\text{Hz}$)		
Power dissipation	P_{tot}	$T_c=25^\circ\text{C}$	192.3	W
Operating and storage temperature	T_j, T_{stg}		-55 to +150	$^\circ\text{C}$

^a Preliminary data sheet - Specifications subject to change.

^b limited by $T_{j\text{max}}$

^c when mounted on 1-inch square 2oz copper-clad FR-4

Parameter	Symbol	Conditions	Values			Unit
			Min	Typ	Max	

Thermal characteristics

Thermal resistance, junction-case	R_{thJC}		-	-	0.65	°C/W
Thermal resistance, junction-ambient °	R_{thJA}	leaded	-	-	55	
Soldering temperature, wave soldering only allowed at leads	T_{sold}	1.6mm (0.063in.) from case for 10 s	-	-	260	°C

Electrical characteristics , at $T_j=25^{\circ}\text{C}$, unless otherwise specified

Static characteristics

Drain-source breakdown voltage	$V_{(BR)DSS}$	$V_{GS}=0\text{ V}, I_D=1\text{ mA}$	600	-	-	V
Gate threshold voltage	$V_{GS(th)}$	$V_{DS}=V_{GS}, I_D=1\text{ mA}$	3	4	5	
Zero gate voltage drain current	I_{DSS}	$V_{DS}=600\text{ V}, V_{GS}=0\text{ V}$	-	-	10	μA
Gate source leakage current	I_{GSS}	$V_{GS}=\pm 30\text{ V}, V_{DS}=0\text{ V}$	-	-	±100	nA
Drain-source on-state resistance	$R_{DS(on)}$	$V_{GS}=10\text{ V}, I_D=15\text{ A}$	-	56	68	mΩ
Gate resistance	R_G	$f=1\text{ MHz}, \text{ open drain}$	-	1.2	-	Ω

Dynamic characteristics

Input capacitance	C_{iss}	$V_{DS}=400\text{ V}, V_{GS}=0\text{ V}, f=1\text{ MHz}$	-	3240	-	pF
Output capacitance	C_{oss}		-	60	-	
Reverse transfer capacitance	C_{rss}		-	3.5	-	
Turn-on delay time	$t_{d(on)}$	$V_{DS}=400\text{ V}, V_{GS}=10\text{ V}, I_D=11\text{ A}, R_G=5.3\Omega$ (External)	-	130	-	ns
Rise time	t_r		-	8	-	
Turn-off delay time	$t_{d(off)}$		-	84	-	
Fall time	t_f		-	11	-	

Parameter	Symbol	Conditions	Values			Unit
			Min	Typ	Max	

Gate charge characteristics

Gate to source charge	Q_{gs}	$V_{DS}=400\text{ V}, I_D=11\text{ A},$ $V_{GS}=0\text{ to }10\text{ V}$	-	19	-	nC
Gate to drain charge	Q_{gd}		-	39	-	
Gate charge total	Q_g		-	83	-	

Reverse Diode

Continuous forward current	I_S	$V_{GS}=0\text{ V}$	-	-	35	A
Diode forward voltage	V_{SD}	$V_{GS}=0\text{ V}, I_S=15\text{ A}$	-	0.95	-	V
Reverse recovery time	t_{rr}	$V_{RR}=400\text{ V}, I_S=11\text{ A},$ $d_{iF}/d_t=100\text{ A}/\mu\text{S}$	-	111	-	ns
Reverse recovery charge	Q_{rr}		-	0.6	-	μC
Peak reverse recovery current	I_{rm}		-	9.3	-	A

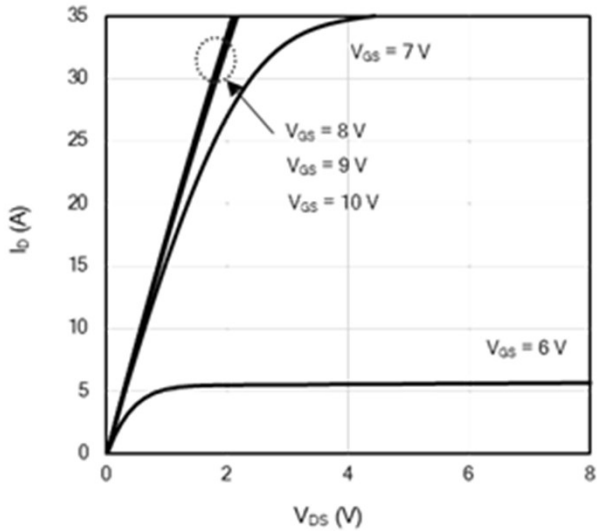

Figure 1: On-Region Characteristics

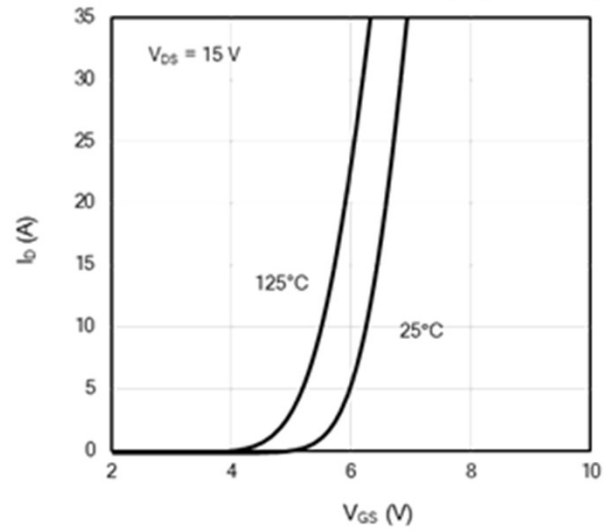

Figure 2: Transfer Characteristics

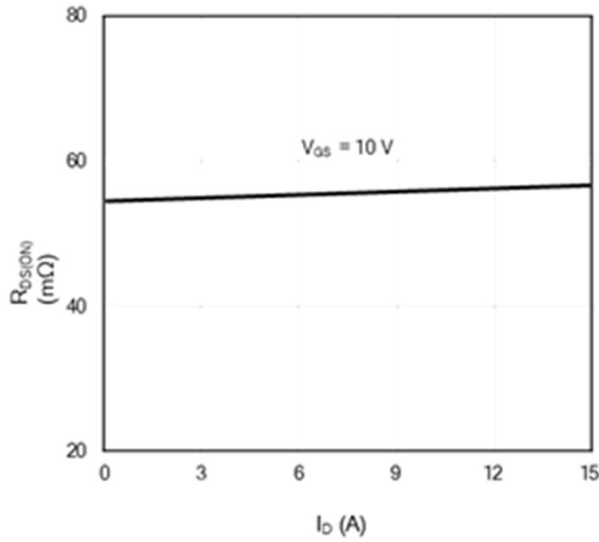

Figure 3: On-Resistance vs. Drain Current and Gate Voltage

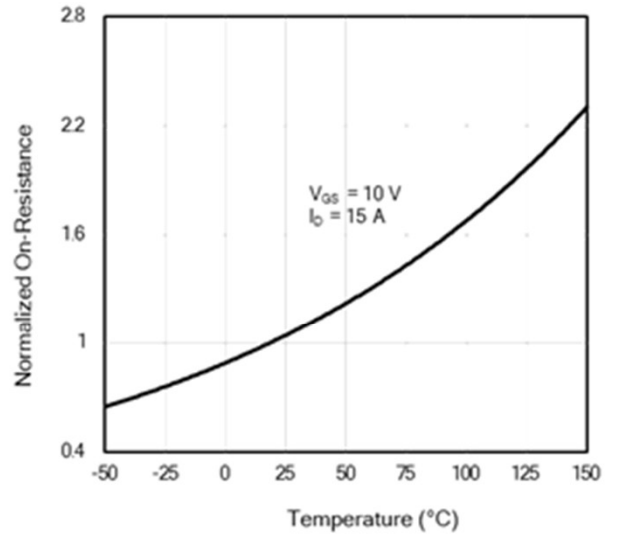

Figure 4: On-Resistance vs. Junction Temperature

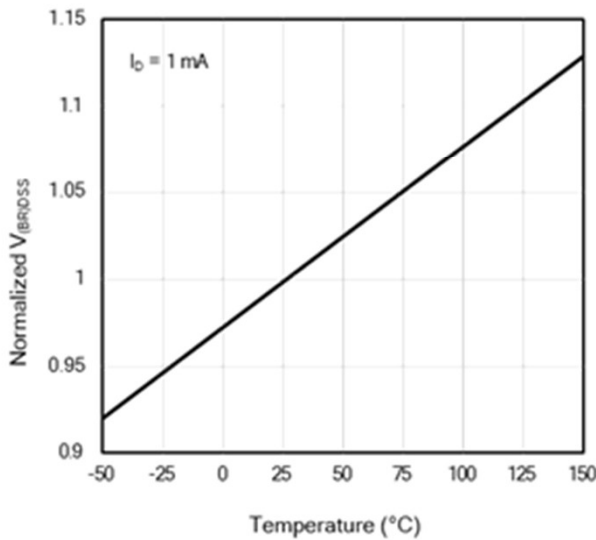

Figure 5: Breakdown Voltage vs. Junction Temperature

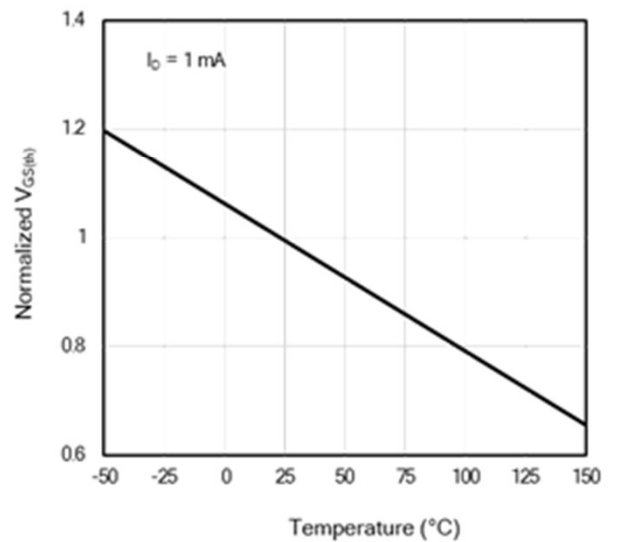

Figure 6: Threshold Voltage vs. Junction Temperature

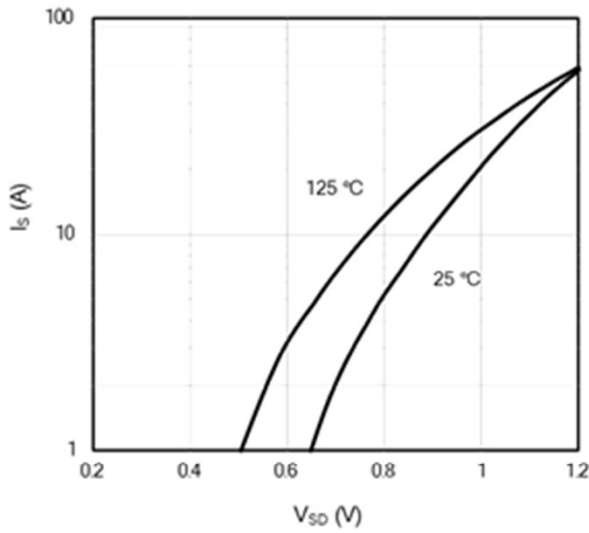

Figure 7: Body-Diode Characteristics

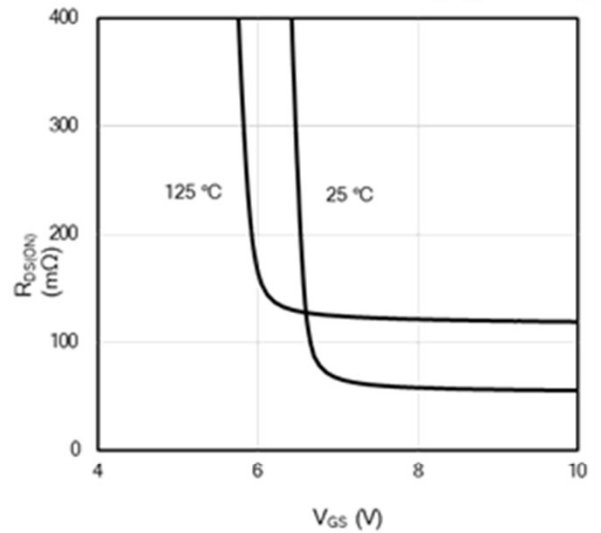

Figure 8: On-Resistance vs. Gate-Source Voltage

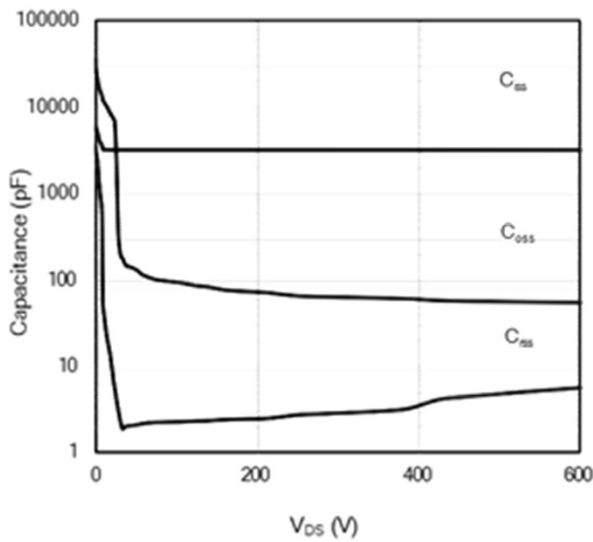

Figure 9: Capacitance Characteristics

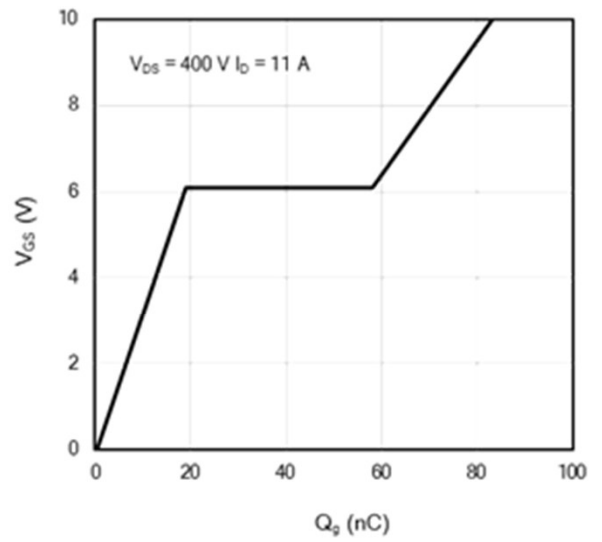

Figure 10: Gate-Charge Characteristics

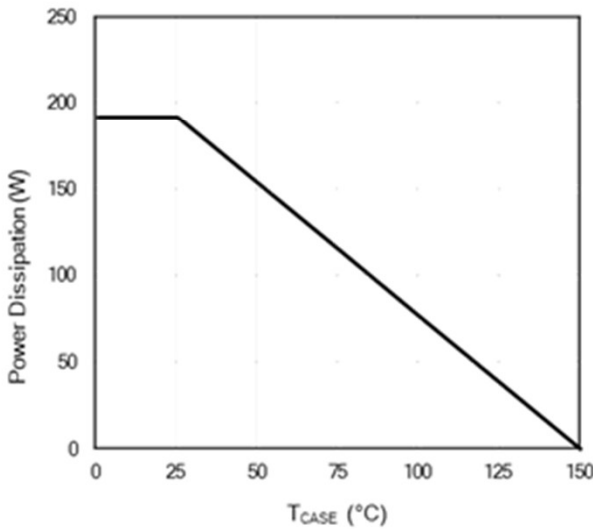

Figure 11: Power De-rating

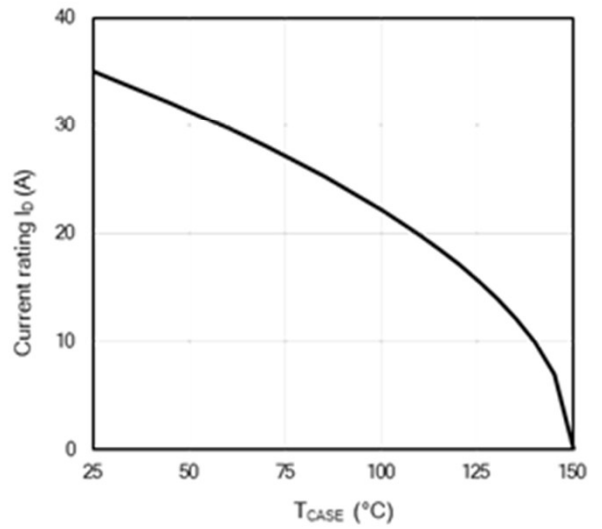

Figure 12: Current De-rating

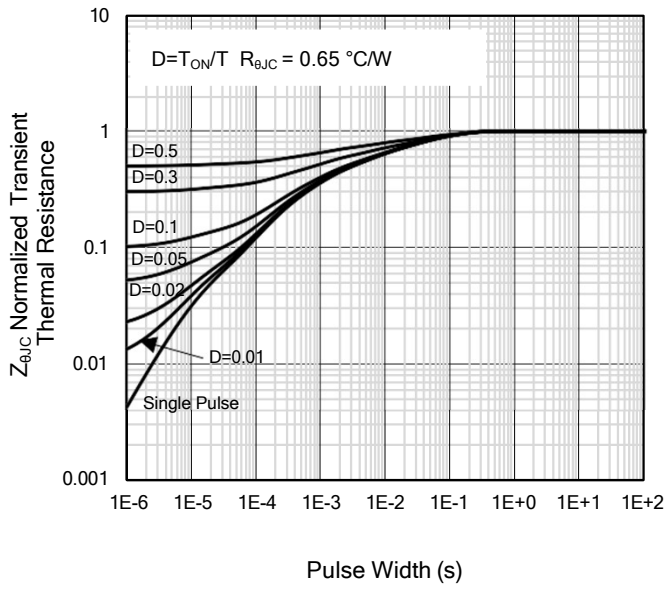

Figure 13: Normalized Maximum Transient Thermal Impedance

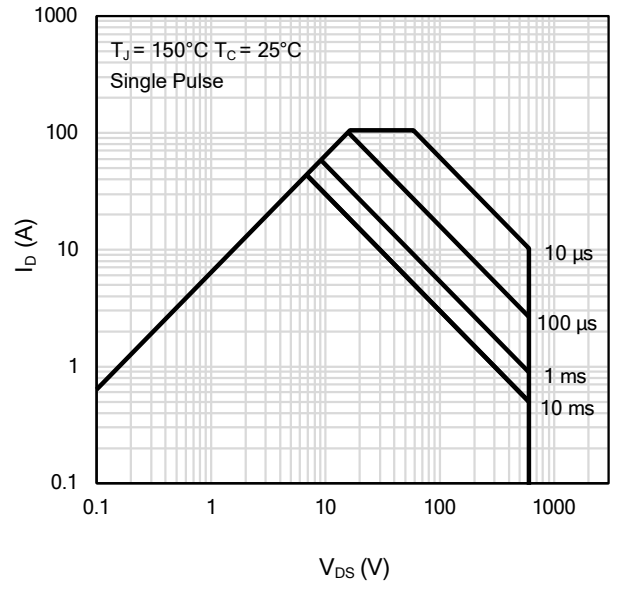

Figure 14: Maximum Forward Biased Safe Operating Area

Marking Information

YY = Last two digits of the year

WW = Work week

***** = Site ID

XXXXXX = Lot ID

ICEK35NF60 = ICE is IceMOS logo and
K35NF60 is a designated device part
number

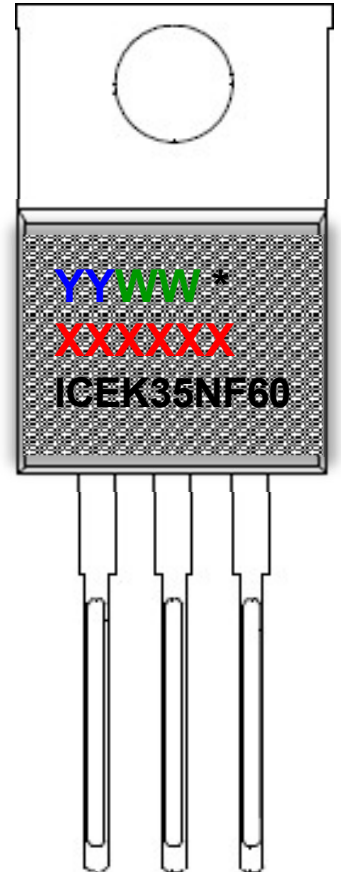

Disclaimer

Information contained in this data sheet shall in no event be regarded as a guarantee of conditions or characteristics. All product, data sheet are subject to change without notice to improve reliability. ICEMOS technology will not be responsible for damages of any nature resulting from the use or reliance upon the information contained in this data sheet.